



## ICPL0600 / ICPL0601

### DESCRIPTION

The ICPL0600 and ICPL0601 devices consist of an infrared emitting diode, optically coupled to a high speed integrated photo detector logic gate with a strobable output.

These devices belong to Isocom Compact Range of Optocouplers.

### FEATURES

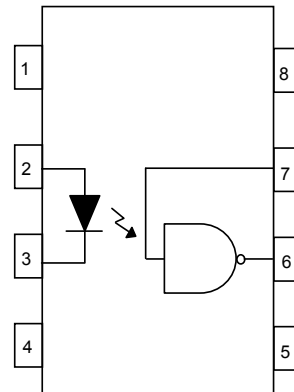
- Half Pitch 1.27mm
- High Speed 10Mbit/s
- High AC Isolation voltage 3750V<sub>RMS</sub>
- Guaranteed Performance from -40°C to 85°C
- Wide Operating Temperature Range -40°C to 100°C
- Logic Gate Output
- Pb Free and RoHS Compliant
- Halogen Free
- Safety Approvals Pending

### APPLICATIONS

- Line Receivers, Data Communication
- LSTTL to TTL, LSTTL or 5V CMOS
- Data Multiplexing
- Pulse Transformer Replacement
- Switch Mode Power Supplies
- Ground Loop Elimination
- Computer Peripheral Interface

### ORDER INFORMATION

- Add T&R after PN for Surface Mount Tape & Reel



1. No Connection
2. Anode
3. Cathode
4. No Connection
5. Gnd
6. Vout
7. V<sub>E</sub>
8. V<sub>CC</sub>

A 0.1µF bypass capacitor must be connected between pins 8 and 5.

### ABSOLUTE MAXIMUM RATINGS (T<sub>A</sub> = 25°C)

#### Input Diode

Forward Current	20mA
Reverse Voltage	5V
Power dissipation	40mW

#### Output

Output Current	50mA
Output Voltage	7.0V
Supply Voltage	7.0V
Enable Input Voltage (maximum 500mV above V <sub>CC</sub> )	5.5V
Enable Input Current	5mA
Power Dissipation	85mW

#### Total Package

Isolation Voltage	3750V <sub>RMS</sub>
Operating Temperature	-40 to 100 °C
Storage Temperature	-55 to 125 °C
Lead Soldering Temperature (10s)	260°C

#### ISOCOM COMPONENTS 2004 LTD

Unit 25B, Park View Road West, Park View Industrial Estate  
Hartlepool, Cleveland, TS25 1UD, United Kingdom  
Tel: +44 (0)1429 863 609 Fax : +44 (0)1429 863 581  
e-mail: sales@isocom.co.uk  
<http://www.isocom.com>

#### ISOCOM COMPONENTS ASIA LTD

Hong Kong Office,  
Block A, 8/F, Wah Hing Industrial mansion,  
36 Tai Yau Street, San Po Kong, Kowloon, Hong Kong.  
Tel: +852 2995 9217 Fax : +852 8161 6292  
e-mail: sales@isocom.com.hk



## ICPL0600 / ICPL0601

### Truth Table (Positive Logic)

Input	Enable	Output
H	H	L
L	H	H
H	L	H
L	L	H
H	NC	L
L	NC	H

### ELECTRICAL CHARACTERISTICS ( $T_A = -40^\circ\text{C}$ to $85^\circ\text{C}$ unless otherwise specified)

#### INPUT

Parameter	Symbol	Test Condition	Min	Typ.*	Max	Unit
Forward Voltage	$V_F$	$I_F = 10\text{mA}$		1.4	1.8	V
Reverse Voltage	$V_R$	$I_R = 10\mu\text{A}$	5.0			V
Temperature Coefficient of $V_F$	$\Delta V_F / \Delta T_A$	$I_F = 10\text{mA}$		-1.8		mV/ $^\circ\text{C}$
Input Capacitance	$C_{IN}$	$V_F = 0\text{V}$ , $f = 1\text{MHz}$		60		pF

#### OUTPUT

Parameter	Symbol	Test Condition	Min	Typ.*	Max	Unit
High Level Supply Current	$I_{CCH}$	$I_F = 0\text{mA}$ , $V_E = 0.5\text{V}$ , $V_{CC} = 5.5\text{V}$			10	mA
Low Level Supply Current	$I_{CCL}$	$I_F = 10\text{mA}$ , $V_{CC} = 5.5\text{V}$			13	mA
High Level Enable Current	$I_{EH}$	$V_E = 2.0\text{V}$ , $V_{CC} = 5.5\text{V}$			-1.6	mA
Low Level Enable Current	$I_{EL}$	$V_E = 0.5\text{V}$ , $V_{CC} = 5.5\text{V}$			-1.6	mA
High Level Enable Voltage	$V_{EH}$	$I_F = 10\text{mA}$ , $V_{CC} = 5.5\text{V}$	2.0			V
Low Level Enable Voltage	$V_{EL}$	$I_F = 10\text{mA}$ , $V_{CC} = 5.5\text{V}$			0.8	V

\* Typical values at  $T_A = 25^\circ\text{C}$



## ICPL0600 / ICPL0601

### ELECTRICAL CHARACTERISTICS ( $T_A = -40^{\circ}\text{C}$ to $85^{\circ}\text{C}$ unless otherwise specified)

#### COUPLED

Parameter	Symbol	Test Condition	Min	Typ.*	Max	Unit
High Level Output Current	$I_{OH}$	$V_{CC} = 5.5\text{V}$ , $V_E = 2.0\text{V}$ , $V_O = 5.5\text{V}$ , $I_F = 250\mu\text{A}$			100	$\mu\text{A}$
Low Level Output Voltage	$V_{OL}$	$V_{CC} = 5.5\text{V}$ , $V_E = 2.0\text{V}$ , $I_F = 5\text{mA}$ , $I_{OL} = 13\text{mA}$			0.6	V
Input Threshold Current	$I_{FT}$	$V_{CC} = 5.5\text{V}$ , $V_E = 2.0\text{V}$ , $V_O = 0.6\text{V}$ , $I_{OL} = 13\text{mA}$			5	mA

### Switching Characteristics ( $T_A = -40^{\circ}\text{C}$ to $85^{\circ}\text{C}$ , $V_{CC} = 5\text{V}$ , $I_F = 7.5\text{mA}$ unless otherwise specified)

Parameter	Symbol	Test Condition	Min	Typ.*	Max	Unit
Propagation Delay Time to Output High Level	$t_{PHL}$	$C_L = 15\text{pF}$ , $R_L = 350\Omega$ , $T_A = 25^{\circ}\text{C}$		35	75	ns
Propagation Delay Time to Output Low level	$t_{PLH}$	$C_L = 15\text{pF}$ , $R_L = 350\Omega$ , $T_A = 25^{\circ}\text{C}$		45	75	ns
Pulse Width Distortion	$ t_{PHL} - t_{PLH} $	$C_L = 15\text{pF}$ , $R_L = 350\Omega$		10	35	ns
Output Rise Time	$t_r$	$C_L = 15\text{pF}$ , $R_L = 350\Omega$		30	40	ns
Output Fall Time	$t_f$	$C_L = 15\text{pF}$ , $R_L = 350\Omega$		10	20	ns
Enable Propagation Delay Time to Output High Level	$t_{ELH}$	$I_F = 7.5\text{mA}$ , $V_{EL} = 0\text{V}$ , $V_{EH} = 3\text{V}$ , $C_L = 15\text{pF}$ , $R_L = 350\Omega$		30	40	ns
Enable Propagation Delay Time to Output Low Level	$t_{EHL}$			20	30	ns

\* Typical values at  $T_A = 25^{\circ}\text{C}$



**ICPL0600 / ICPL0601**

**ELECTRICAL CHARACTERISTICS ( $T_A = -40^\circ\text{C}$  to  $85^\circ\text{C}$  unless otherwise specified)**

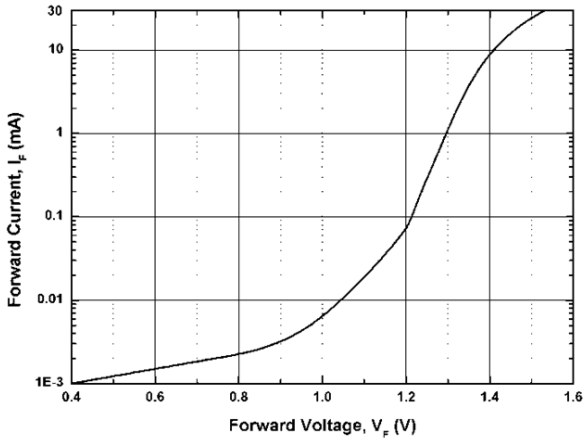
**Switching Characteristics ( $T_A = -40^\circ\text{C}$  to  $85^\circ\text{C}$ ,  $V_{CC} = 5\text{V}$ ,  $I_F = 7.5\text{mA}$  unless otherwise specified)**

Parameter	Symbol	Test Condition	Min	Typ.*	Max	Unit
Common Mode Transient Immunity at Logic High	CM <sub>H</sub>	ICPL0600 (Fig 14) $I_F = 0\text{mA}$ , $V_{OH} = 2\text{V}$ , $R_L = 350\Omega$ , $V_{CM} = 10\text{Vp-p}$ , $T_A = 25^\circ\text{C}$				V/ $\mu\text{s}$
		ICPL0601 (Fig 14) $I_F = 0\text{mA}$ , $V_{OH} = 2\text{V}$ , $R_L = 350\Omega$ , $V_{CM} = 50\text{Vp-p}$ , $T_A = 25^\circ\text{C}$	5000			
Common Mode Transient Immunity at Logic Low	CM <sub>L</sub>	ICPL0600 (Fig 14) $I_F = 7.5\text{mA}$ , $V_{OL} = 0.8\text{V}$ , $R_L = 350\Omega$ , $V_{CM} = 10\text{Vp-p}$ , $T_A = 25^\circ\text{C}$				V/ $\mu\text{s}$
		ICPL0601 (Fig 14) $I_F = 7.5\text{mA}$ , $V_{OL} = 0.8\text{V}$ , $R_L = 350\Omega$ , $V_{CM} = 50\text{Vp-p}$ , $T_A = 25^\circ\text{C}$	5000			

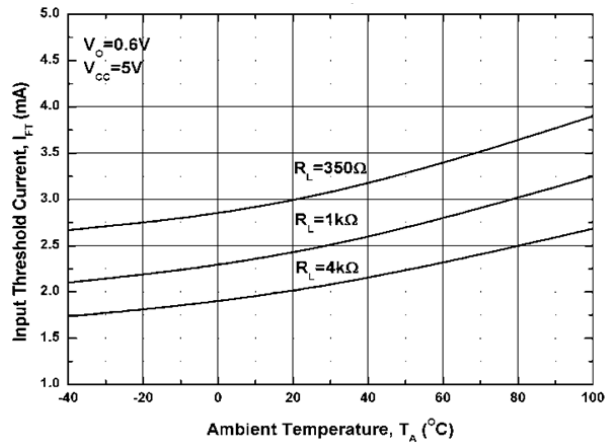
\* Typical values at  $T_A = 25^\circ\text{C}$



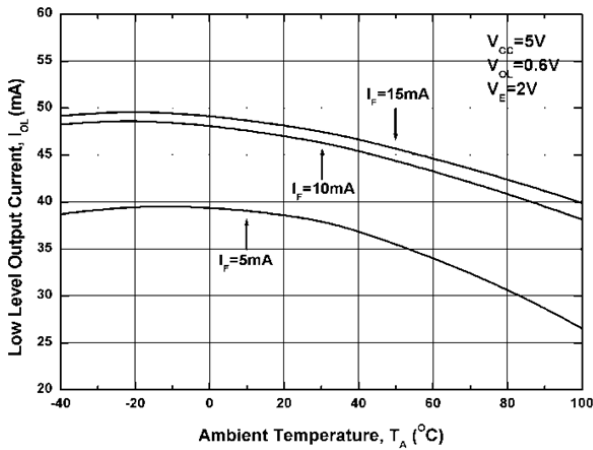
**ICPL0600 / ICPL0601**



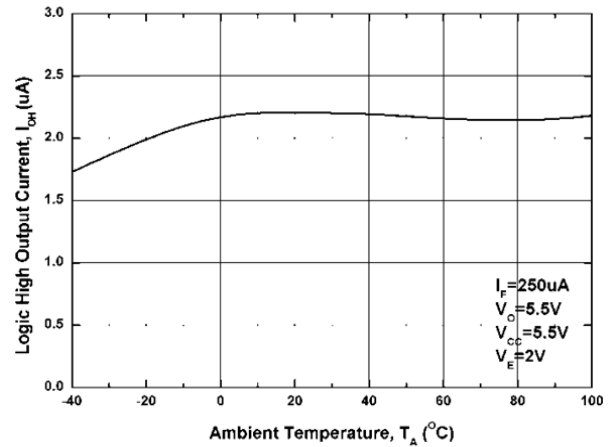
**Fig 1 Forward Current vs Forward Voltage**



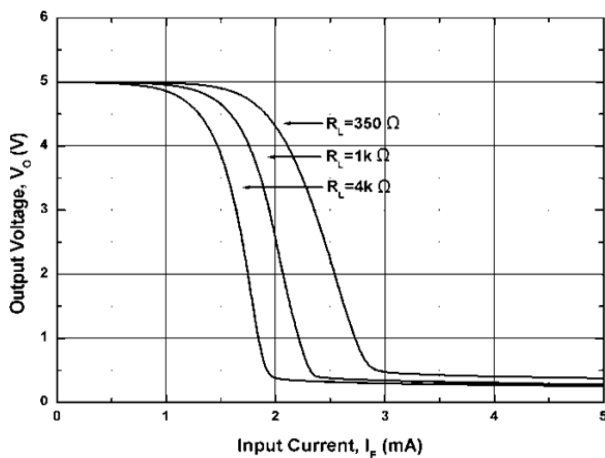
**Fig 2 Input Threshold Current vs T<sub>A</sub>**



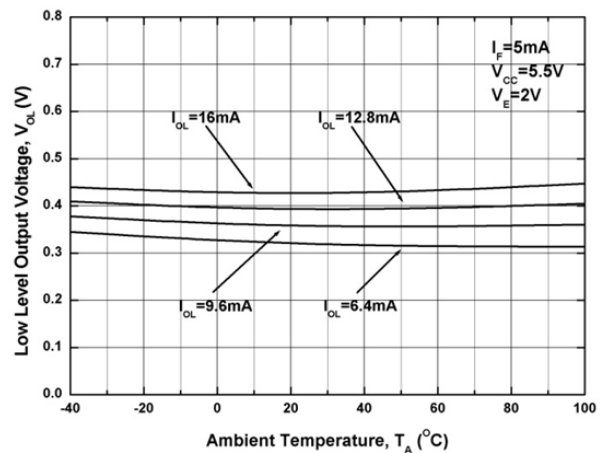
**Fig 3 Low Level Output Current vs T<sub>A</sub>**



**Fig 4 High Level Output Current vs T<sub>A</sub>**



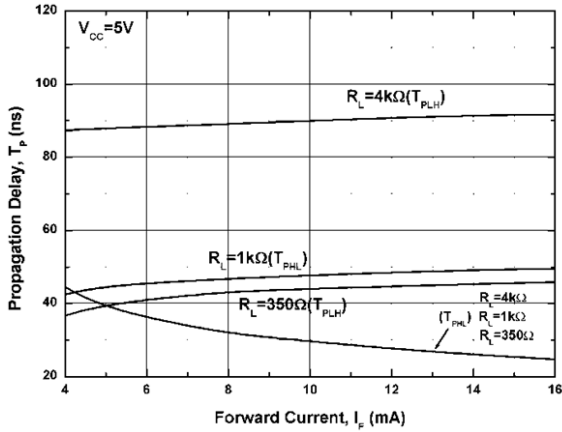
**Fig 5 Output Voltage vs Input Forward Current**



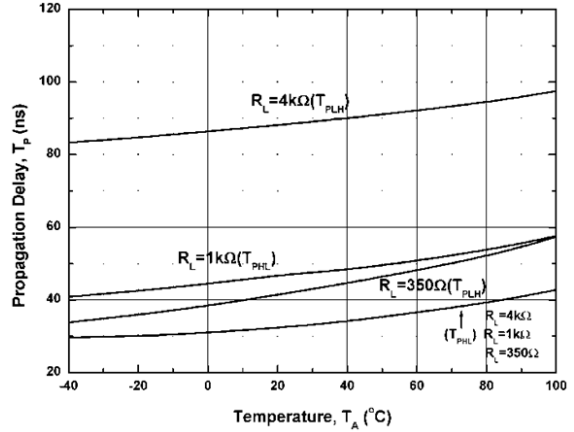
**Fig 6 Low Level Output Voltage vs T<sub>A</sub>**



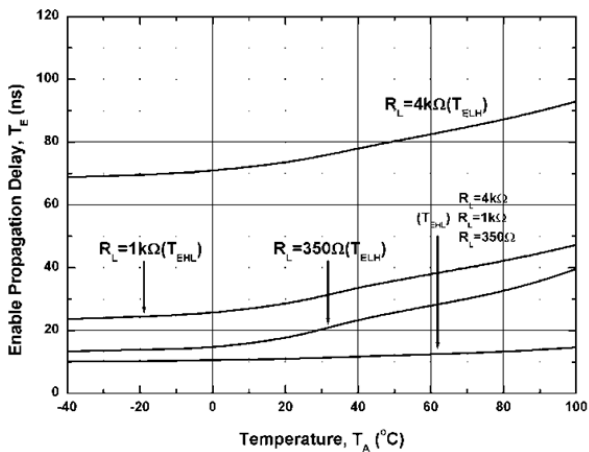
**ICPL0600 / ICPL0601**



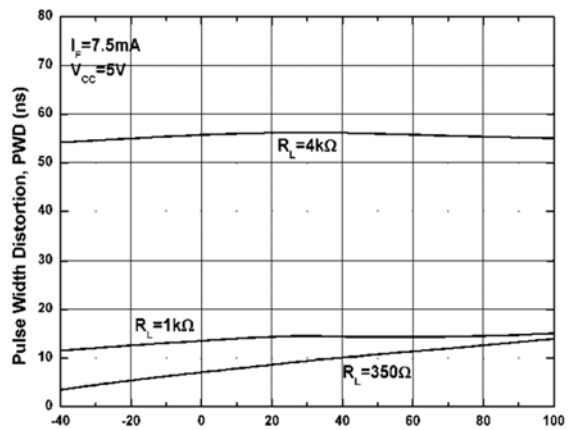
**Fig 7 Propagation Delay Time vs Forward Current**



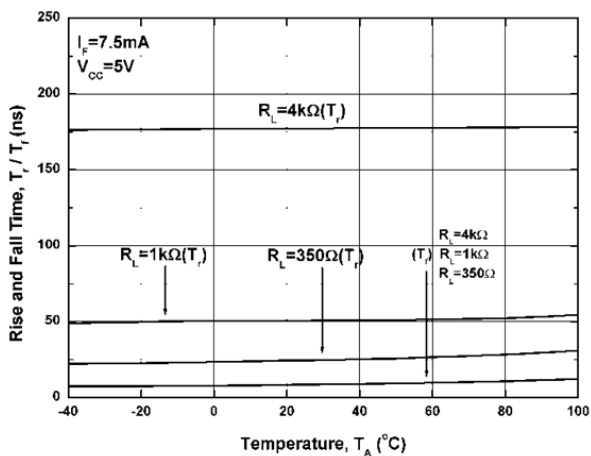
**Fig 8 Propagation Delay Time vs  $T_A$**



**Fig 9 Enable Propagation Delay Time vs  $T_A$**



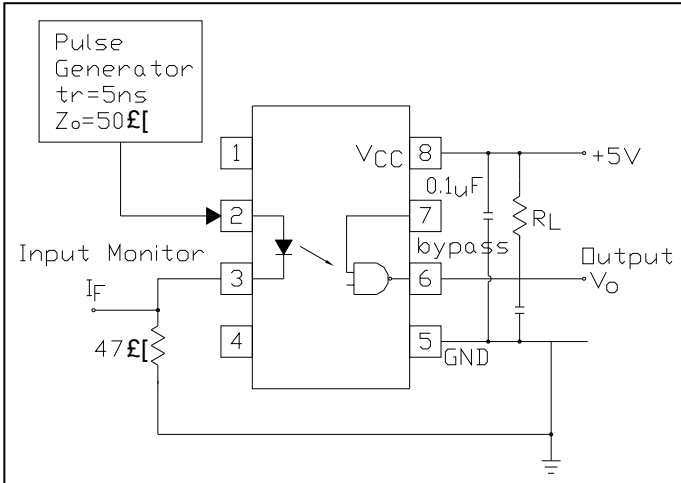
**Fig 10 Pulse Width Distortion vs  $T_A$**



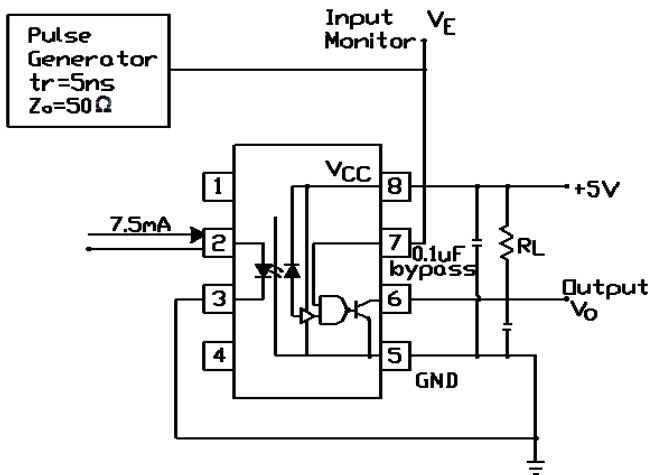
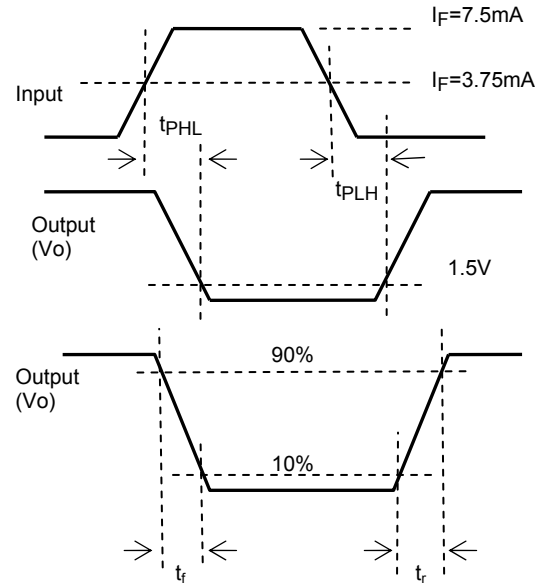
**Fig 11 Rise Time / Fall Time vs  $T_A$**



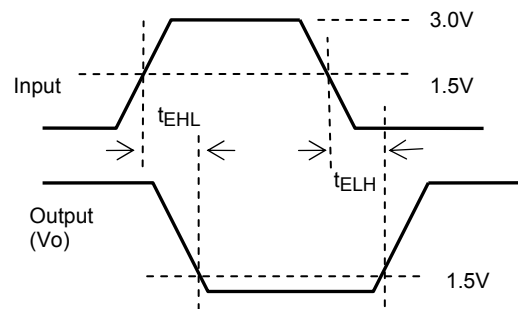
**ICPL0600 / ICPL0601**



**Fig 12  $t_{PHL}$ ,  $t_{PLH}$ ,  $t_r$  and  $t_f$  Test Circuit**

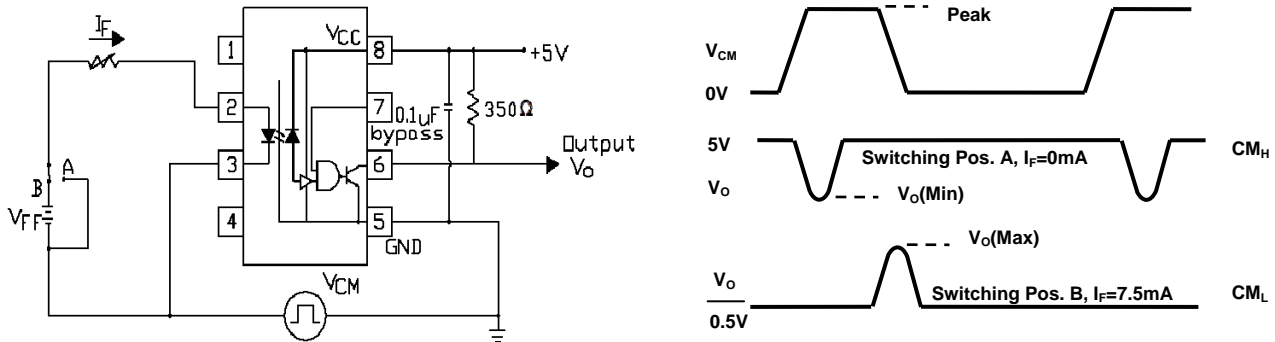


**Fig 13  $t_{EHL}$  and  $t_{ELH}$  Test Circuit**

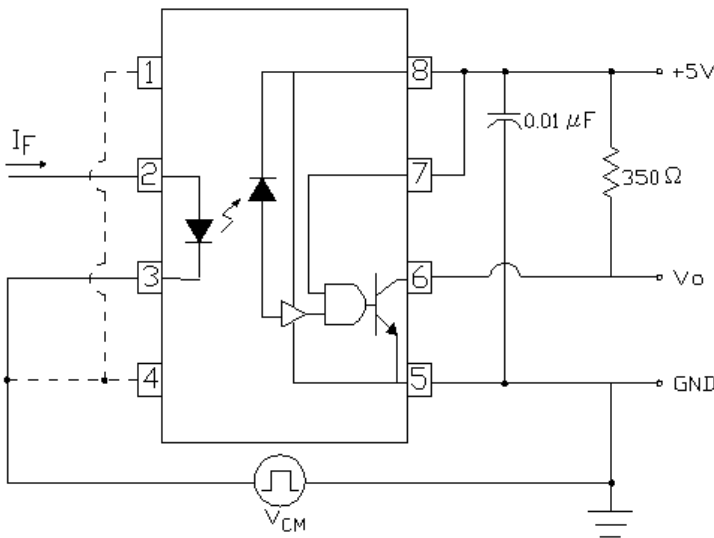




**ICPL0600 / ICPL0601**



**Fig 14 Common Mode Transient Immunity Test Circuit**



**Fig 15 High Common Mode Transient Immunity Test Circuit**

Common mode transient immunity in logic high level is the maximum tolerable (positive)  $dV_{CM}/dt$  on the leading edge of the common mode pulse signal  $V_{CM}$ , to assure that the output will remain in a logic high state (i.e.,  $V_O > 2.0V$ ).

Common mode transient immunity in logic low level is the maximum tolerable (negative)  $dV_{CM}/dt$  on the trailing edge of the common mode pulse signal,  $V_{CM}$ , to assure that the output will remain in a logic low state (i.e.,  $V_O < 0.8V$ ).



## ICPL0600 / ICPL0601

### Notes:

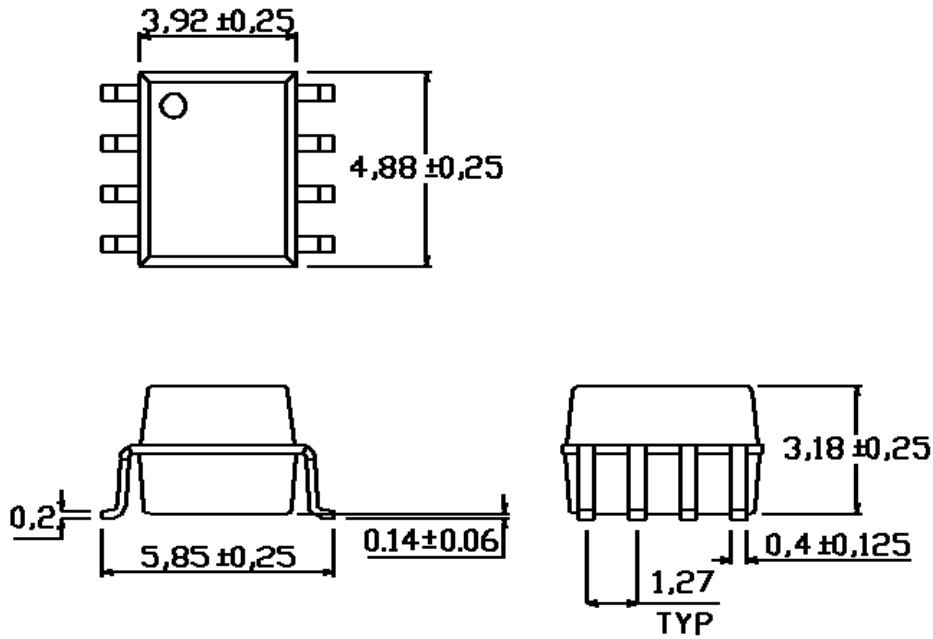
- The  $V_{CC}$  supply must be bypassed by a  $0.1\mu\text{F}$  capacitor or larger with good high frequency characteristic and should be connected as close as possible to the package  $V_{CC}$  and GND pins.
- Enable Input – No pull up resistor required as the device has an internal pull up resistor.
- $t_{PLH}$  is measured from the  $3.75\text{mA}$  level on the HIGH to LOW transition of the input current pulse to the  $1.5\text{ V}$  level on the LOW to HIGH transition of the output voltage pulse.
- $t_{PHL}$  is measured from the  $3.75\text{mA}$  level on the LOW to HIGH transition of the input current pulse to the  $1.5\text{ V}$  level on the HIGH to LOW transition of the output voltage pulse.
- $t_r$  Rise time is measured from the 10% to the 90% levels on the LOW to HIGH transition of the output pulse.
- $t_f$  Fall time is measured from the 90% to the 10% levels on the HIGH to LOW transition of the output pulse.
- $t_{ELH}$  is measured from the  $1.5\text{V}$  level on the HIGH to LOW transition of the input Enable voltage pulse to the  $1.5\text{V}$  level on the LOW to HIGH transition of the output voltage pulse.
- $t_{EHL}$  is measured from the  $1.5\text{V}$  level on the LOW to HIGH transition of the input Enable voltage pulse to the  $1.5\text{V}$  level on the HIGH to LOW transition of the output voltage pulse.
- $CM_H$ – The maximum tolerable rate of rise of the common mode voltage to ensure the output will remain in the HIGH state (i.e.,  $V_O > 2.0\text{V}$ ).
- $CM_L$ – The maximum tolerable rate of rise of the common mode voltage to ensure the output will remain in the LOW output state (i.e.,  $V_O < 0.8\text{V}$ ).



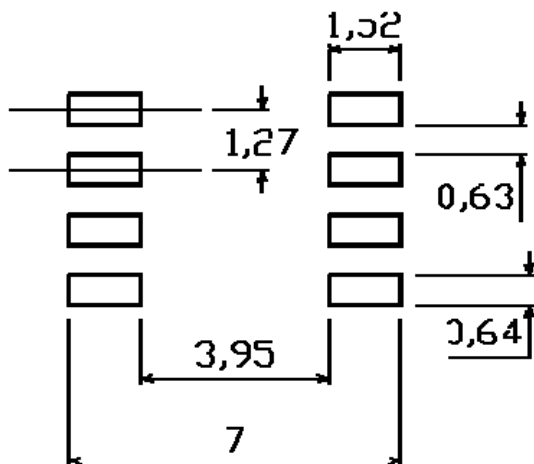


**ICPL0600 / ICPL0601**

**PACKAGE DIMENSIONS (mm)**



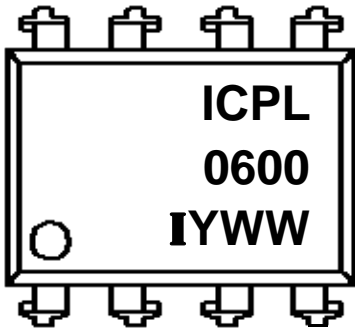
**Recommended Solder Pad Layout (mm)**





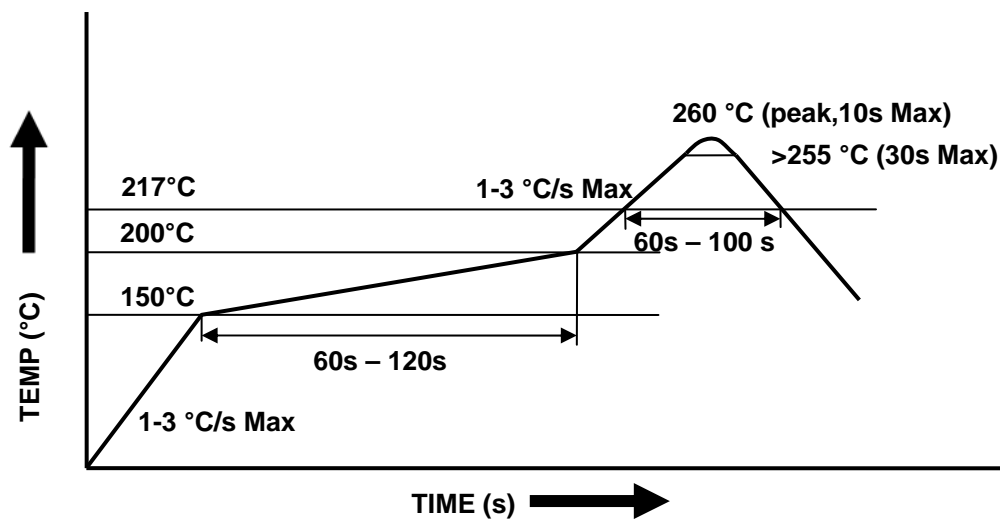
## ICPL0600 / ICPL0601

### Device Marking (Example ICPL0600)



ICPL0600 denotes Device Part Number  
Y denotes 1 digit Year code  
WW denotes 2 digit Week code  
I denotes Isocom

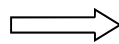
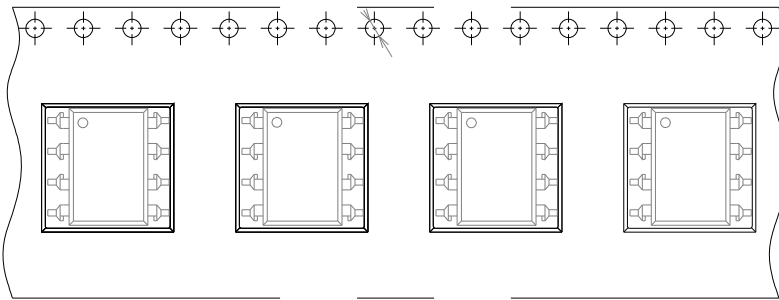
### REFLOW SOLDERING TEMPERATURE PROFILE



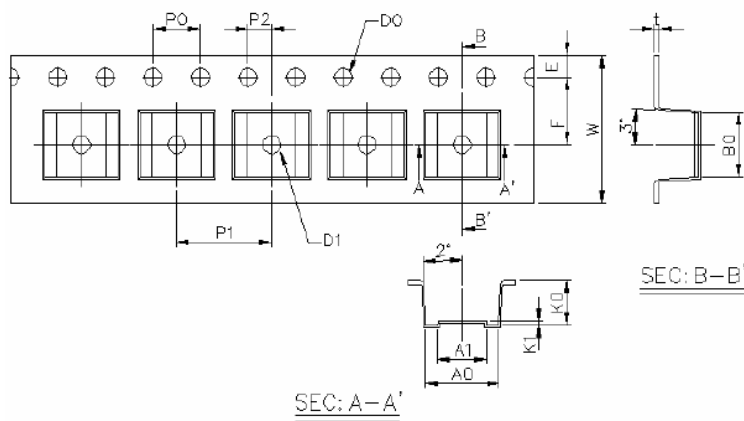


**ICPL0600 / ICPL0601**

**Tape and Reel Packaging**



Direction of feed from reel



Dimension No.	<b>A0</b>	<b>A1</b>	<b>B0</b>	<b>D0</b>	<b>D1</b>	<b>E</b>	<b>F</b>
Dimension (mm)	6.2±0.1	4.1±0.1	5.28±0.1	1.5±0.1	1.5±0.3	1.75±0.1	5.5±0.1
Dimension No.	<b>Po</b>	<b>P1</b>	<b>P2</b>	<b>t</b>	<b>W</b>	<b>K0</b>	<b>K1</b>
Dimension (mm)	4.0±0.1	8.0±0.1	2.0±0.1	0.4±0.1	12.0 +0.3/-0.1	3.7±0.1	0.3±0.1