



ISSR11800X



DESCRIPTION

The ISSR11800X is a high-performance single-channel solid-state relay that integrates a silicon carbide (SiC) MOSFET and an AlGaAs infrared LED.

This compact device achieves efficient optical coupling and isolation through a photovoltaic generator, ensuring reliable signal transfer between input and output circuits.

With a voltage rating of 1800V and an isolation rating of 5000Vrms, the ISSR11800X offers robust performance in a durable 5-pin package.

FEATURES

- High peak load voltage of 1,800V (AC/DC)
- 5,000Vrms reinforced isolation between input and output
- Low, stable on-resistance for reliable operation
- SMD-formed DIP-5 package
- UL 1577 Pending Approval
- VDE DIN EN60747-5-5 Pending Approval
- MSL Class 1
- Automotive-grade AEC-Q101 qualified

APPLICATIONS

- Ideal for controlling various loads, including relays, motors, lamps, and solenoids
- Static AC power switching applications
- Battery Management Systems (BMS) with flying capacitor topology for battery sensing
- Precision measuring instruments
- Data communication and IT equipment applications
- EV & Hybrid Electric Industry

Pin No. and Internal connection diagram

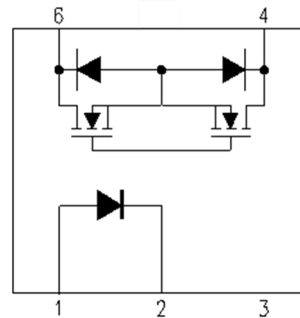

1. Anode
2. Cathode
4. Drain
6. Drain

ABSOLUTE MAXIMUM RATINGS (T_A = 25°C)

Stresses exceeding the absolute maximum ratings can cause permanent damage to the device. Exposure to absolute maximum ratings for long periods of time can adversely affect reliability.

Input

| | |
|----------------------|-------|
| Forward Current | 50mA |
| Reverse Voltage | 5V |
| Power dissipation | 75mW |
| Junction Temperature | 135°C |

Output

| | |
|-----------------------------------|-------|
| Load Voltage (Peak AC & DC) | 1800V |
| Cont. Load Current (Peak AC & DC) | 20mA |
| Power Dissipation | 360mW |
| Junction Temperature | 175°C |

Total Package

| | |
|----------------------------------|----------------------|
| Isolation Voltage | 5000V _{RMS} |
| Total Power Dissipation | 410mW |
| Operating Temperature | -40 to 125°C |
| Storage Temperature | -55 to 150 °C |
| Lead Soldering Temperature (10s) | 260°C |

ISOCOM COMPONENTS 2004 LTD

Unit 25B, Park View Road West, Park View Industrial Estate
Hartlepool, Cleveland, TS25 1PE, United Kingdom
Tel : +44 (0)1429 863 609 Fax : +44 (0)1429 863 581
e-mail : sales@isocom.co.uk
<http://www.isocom.com>

ISOCOM COMPONENTS ASIA LTD

Hong Kong Office
Block A, 8/F, Wah Hing Industrial Mansions
36 Tai Yau Street, San Po Kong, Kowloon, Hong Kong
Tel : +852 2995 9217 Fax : +852 8161 6292
e-mail : sales@isocom.com.hk



Recommended Operating Conditions

| Parameter | Symbol | Min | Typ | Max | Unit |
|-----------------------|-----------|-----|-----|------|------|
| Load Voltage | V_L | - | - | 1500 | V |
| Forward Current | I_F | 5 | 10 | 25 | mA |
| Load Current | I_{ON} | - | - | 20 | mA |
| Operating Temperature | T_{opr} | -20 | - | 105 | °C |

NOTE :

Recommended operating conditions are given as a design guideline to obtain expected performance of the device.

Each item is an independent guideline.

Please also refer to specified characteristics in this document.



ISSR11800X

ELECTRICAL CHARACTERISTICS ($T_A = 25^\circ\text{C}$ unless otherwise specified)

INPUT

| Parameter | Symbol | Test Condition | Min | Typ. | Max | Unit |
|-----------------|--------|-------------------|-----|------|------|---------------|
| Forward Voltage | V_F | $I_F=10\text{mA}$ | - | 1.45 | 1.75 | V |
| Reverse Current | I_R | $V_R=5\text{V}$ | - | - | 10 | μA |

OUTPUT

| Parameter | Symbol | Test Condition | Min | Typ. | Max | Unit |
|-------------------|------------|---------------------------------------|-----|------|-----|---------------|
| OFF-State Current | I_{Leak} | $I_F=0\text{mA}$, $V_L=1500\text{V}$ | - | - | 10 | μA |

COUPLED

| Parameter | Symbol | Test Condition | Min | Typ. | Max | Unit |
|---------------------|------------|--|-----|------|-----|----------|
| Trigger LED Current | I_{FT} | $I_L=20\text{mA}$ | - | 0.8 | 3 | mA |
| Return LED Current | I_{Foff} | $I_{OFF}=10\mu\text{A}$ | 0.1 | - | - | mA |
| On Resistance | R_{ON} | $I_F=10\text{mA}$ $I_{ON}=20\text{mA}$ $t < 1\text{s}$ | - | 15 | 100 | Ω |

TRANSFER

| Parameter | Symbol | Test Condition | Min | Typ. | Max | Unit |
|----------------------------|-----------|--|-------------------|------|-----|----------|
| Turn on time ¹ | T_{ON} | $I_F=10\text{mA}$, $V_{CC}=10\text{V}$ $R_L=100\Omega$ | - | 0.5 | 1.0 | ms |
| Turn off time ¹ | T_{OFF} | $I_F=10\text{mA}$, $V_{CC}=10\text{V}$ $R_L=100\Omega$ | - | 0.05 | 0.2 | ms |
| Isolation Resistance | R_{ISO} | DC500V, R.H.40 ~ 60% | $1 \cdot 10^{11}$ | - | - | Ω |

Note¹- Turn on/off time:

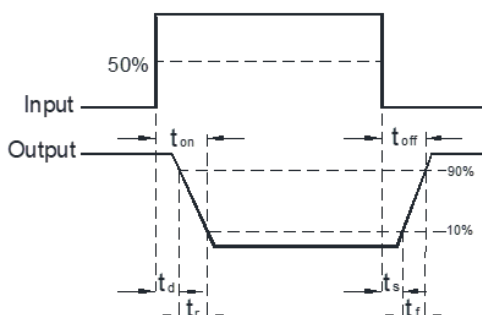



ISSR11800X

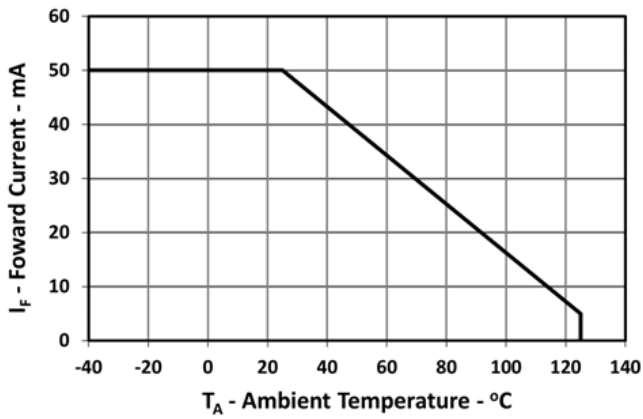

Fig 1 Forward Current vs Ambient Temperature

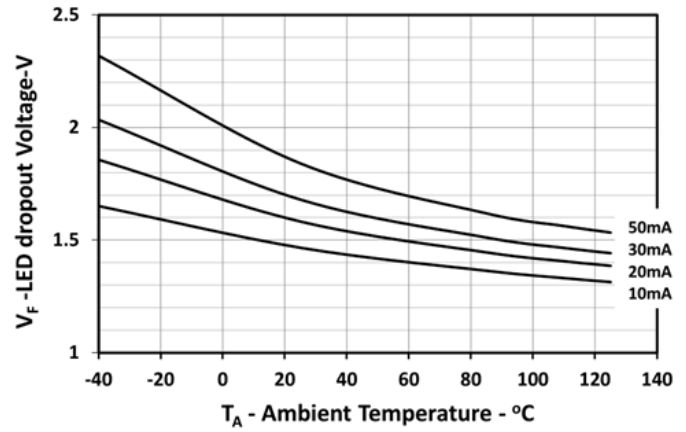

Fig. 2 Dropout Voltage vs. Ambient Temperature

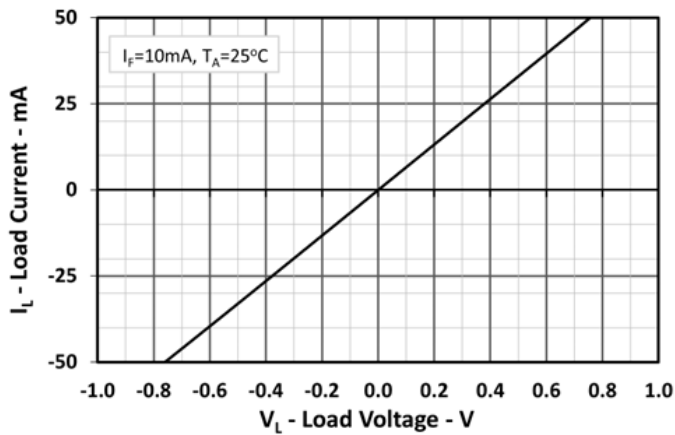

Fig. 3 On-State Current vs On-State Voltage



Fig 4 Switching Time vs Forward Current

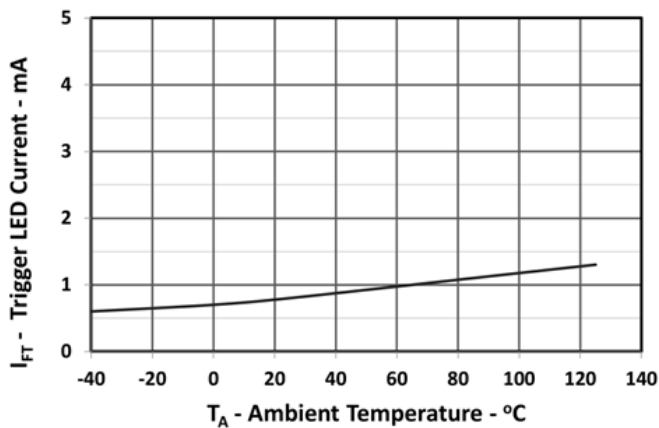

Fig. 5 Trigger Current vs Ambient Temperature

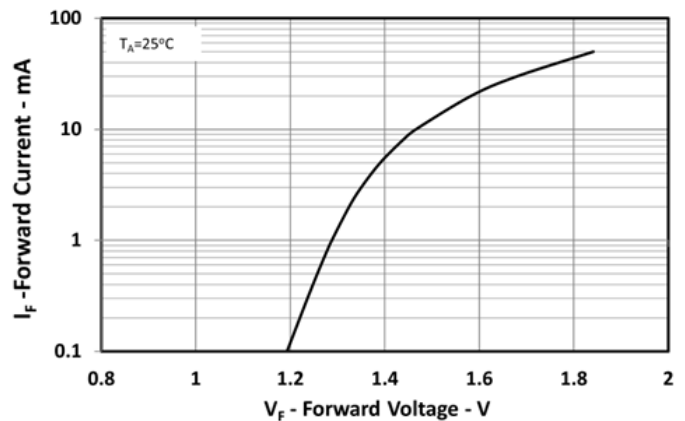

Fig. 6 Forward Current vs Forward Voltage



ISOCOM
COMPONENTS

ISSR11800X

ORDER INFORMATION

| ISSR11800X | | | |
|------------|-----------------|------------------|----------------------|
| After PN | PN | Description | Packing quantity |
| None | ISSR11800XSMT&R | SMT-Formed 5-Pin | Tape & Reel 1000 pcs |



ISOCOM
COMPONENTS

ISSR11800X

DEVICE MARKING

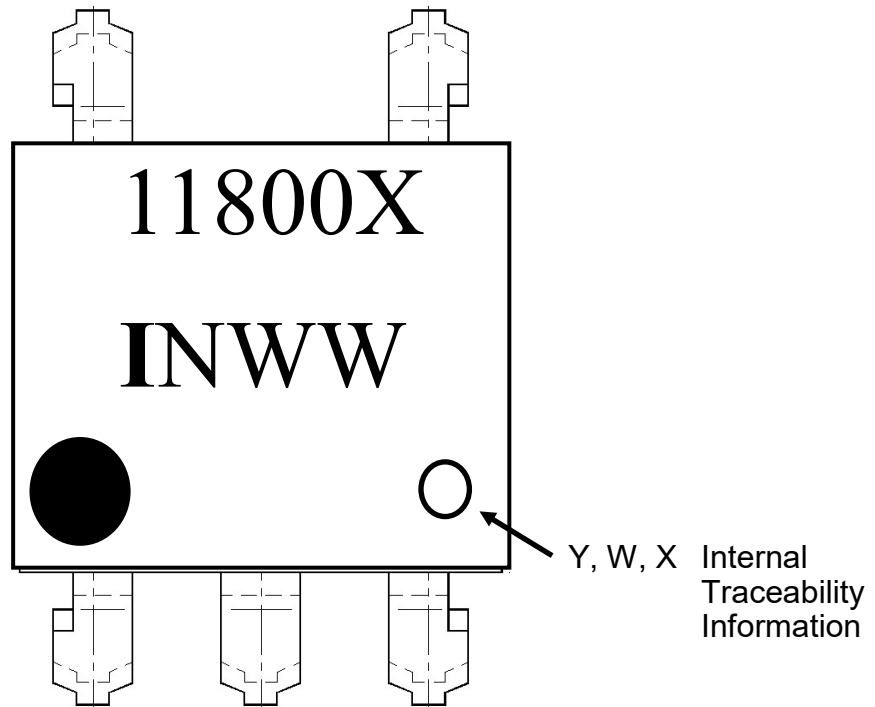

| | |
|--------|--|
| 11800X | Device Part Number |
| I | Isocom Components 2004 Ltd. |
| N | Year code (A= 2010, B = 2011, etc.) |
| WW | 2 digit Week code |



ISSR11800X

PACKAGE DIMENSIONS in mm (inch)

DIP

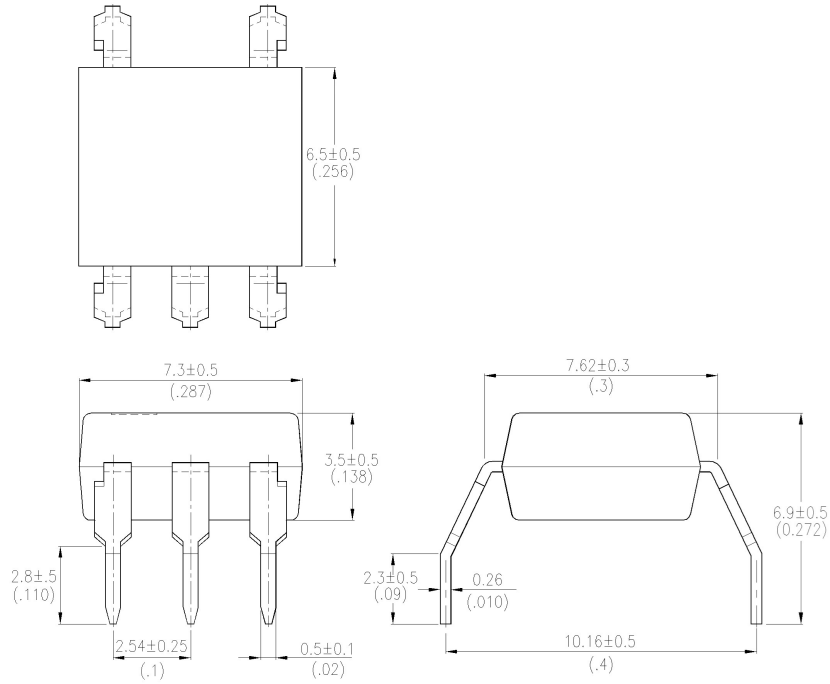

SMD

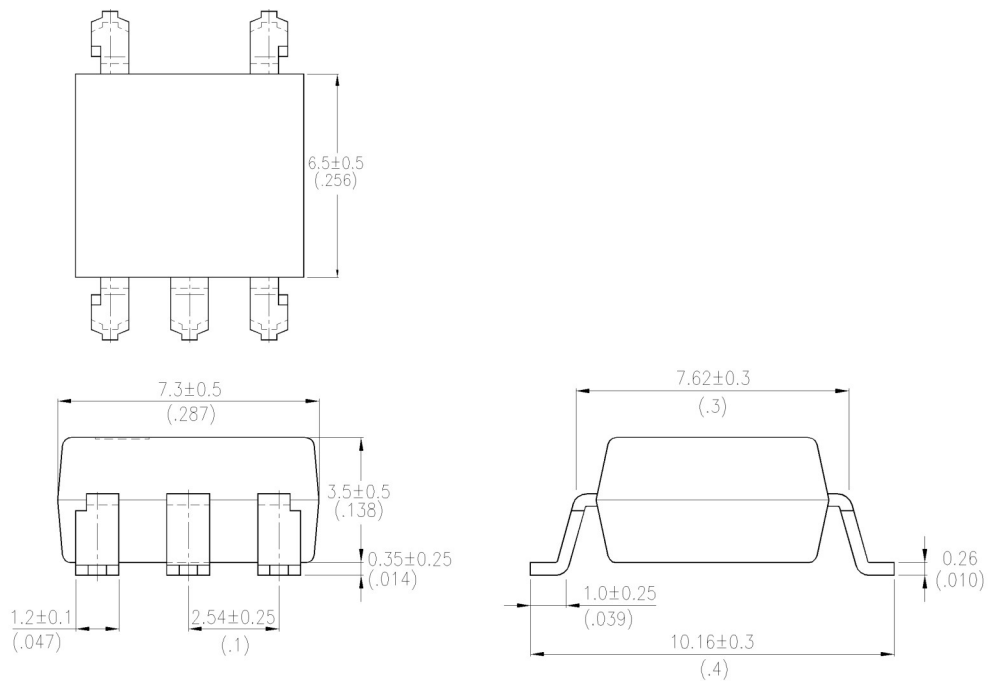



ISSR11800X

RECOMMENDED PAD LAYOUT FOR SMD (mm)

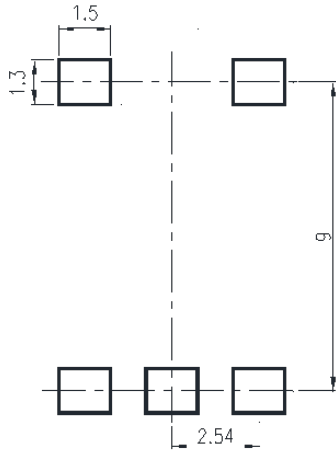

TAPE AND REEL PACKAGING

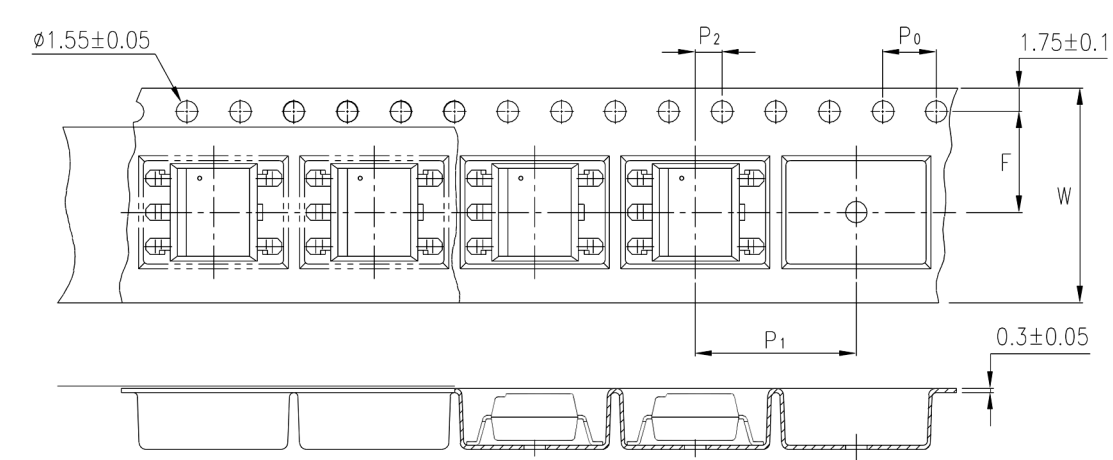

| Description | Symbol | Dimension mm (inch) |
|---|----------------|------------------------|
| Tape Width | W | 16 ± 0.3 (0.63) |
| Pitch of Sprocket Holes | P ₀ | 4 ± 0.1 (0.15) |
| Distance of Compartment to Sprocket Holes | F | 7.5 ± 0.1 (0.295) |
| | P ₂ | 2 ± 0.1 (0.079) |
| Distance of Compartment to Compartment | P ₁ | 12 ± 0.1 (0.472) |



IR REFLOW SOLDERING TEMPERATURE PROFILE

Note : One Time Reflow Soldering is Recommended.
Do Not Immerse Device Body in Solder Paste.

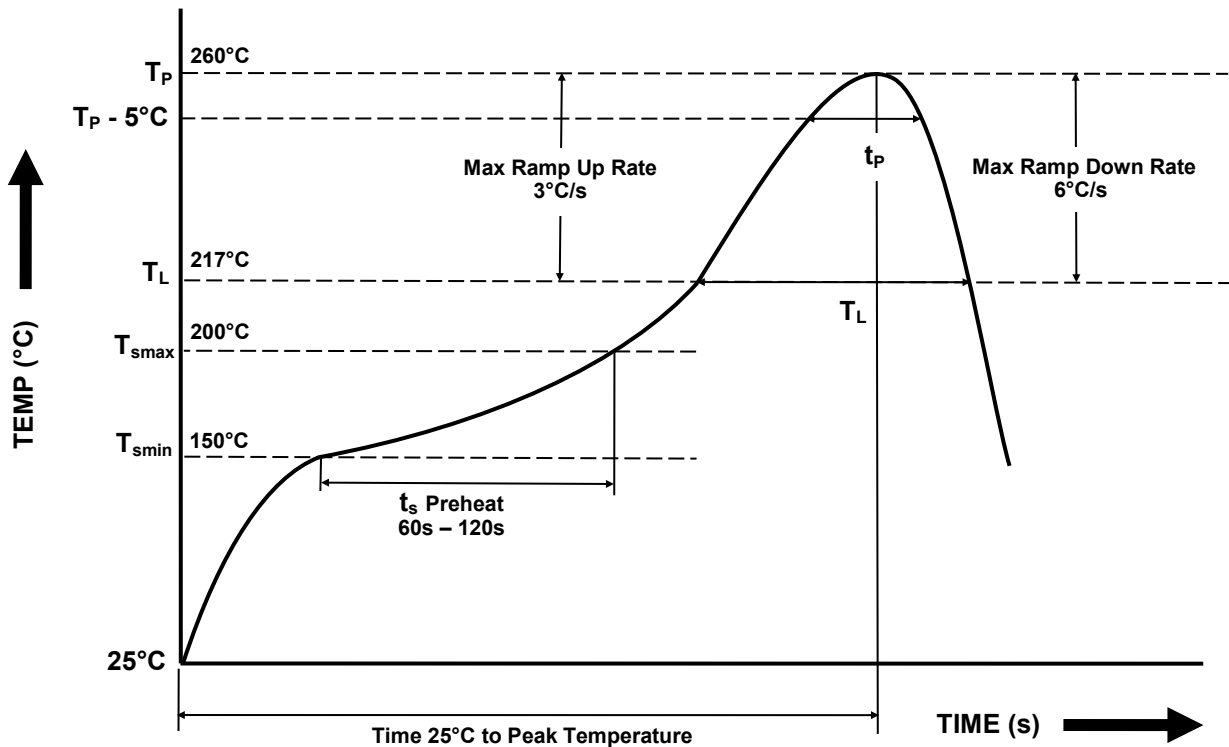

| Profile Details | Conditions |
|---|--|
| Preheat - Min Temperature (T _{SMIN}) - Max Temperature (T _{SMAX}) - Time T _{SMIN} to T _{SMAX} (t _s) | 150°C 200°C 60s - 120s |
| Soldering Zone - Peak Temperature (T _P) - Time at Peak Temperature - Liquidous Temperature (T _L) - Time within 5°C of Actual Peak Temperature (T _P - 5°C) - Time maintained above T _L (t _L) - Ramp Up Rate (T _L to T _P) - Ramp Down Rate (T _P to T _L) | 260°C 10s max 217°C 30s max 60s - 100s 3°C/s max 6°C/s max |
| Average Ramp Up Rate (T _{smax} to T _P) | 3°C/s max |
| Time 25°C to Peak Temperature | 8 minutes max |



DISCLAIMER

Isocom Components is continually working to improve the quality and reliability of its products. Nevertheless, semiconductor devices in general can malfunction or fail due to their inherent electrical sensitivity and vulnerability to physical stress. It is the responsibility of the buyer, when utilizing Isocom Components products, to comply with the standards of safety in making a safe design for the entire system, and to avoid situations in which a malfunction or failure of such Isocom Components products could cause loss of human life, bodily injury or damage to property.

In developing your designs, please ensure that Isocom Components products are used within specified operating ranges as set forth in the most recent Isocom Components products specifications.

The Isocom Components products listed in this document are intended for usage in general electronics applications (computer, personal equipment, office equipment, measuring equipment, industrial robotics, domestic appliances, etc.). These Isocom Components products are neither intended nor warranted for usage in equipment that requires extraordinarily high quality and/or reliability or a malfunction or failure of which may cause loss of human life or bodily injury ("Unintended Usage"). Unintended Usage include atomic energy control instruments, airplane or spaceship instruments, transportation Instruments, traffic signal instruments, combustion control instruments, medical Instruments, all types of safety devices, etc... Unintended Usage of Isocom Components products listed in this document shall be made at the customer's own risk.

The products described in this document are subject to the foreign exchange and foreign trade laws.

The information contained herein is presented only as a guide for the applications of our products. No responsibility is assumed by Isocom Components for any infringements of intellectual property or other rights of the third parties which may result from its use. No license is granted by implication or otherwise under any intellectual property or other rights of Isocom Components or others.

The information contained herein is subject to change without notice.



Document Change Log

| Date | Document Number | Change |
|------------|-----------------|-----------------|
| 07/07/2025 | DN93331-01 | Initial Release |
| | | |
| | | |