



ISPQ9185X



DESCRIPTION

The ISPQ9185X is a high-performance single-channel optocoupler in an MINI-FLAT SMT package, designed to provide reliable signal transmission and noise isolation.

With a 3750Vrms isolation rating, this optocoupler ensures robust performance, even in electrically noisy environments.

The device offers a wide Current Transfer Ratio (CTR) range from 50% to 600% at $I_F = 5\text{mA}$, $V_{CE} = 5\text{V}$, making it suitable for various signal transmission applications.

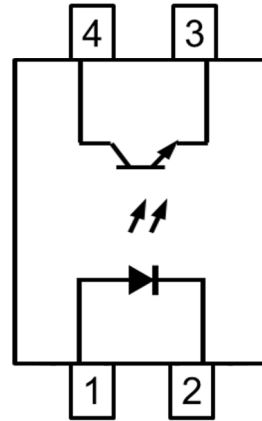

1. Anode
2. Cathode
3. Emitter
4. Collector

KEY FEATURES

- Qualified to AEC-Q102 for automotive-grade reliability (Class 1)
- Wide Current Transfer Ratio (CTR) range: 50% to 600% at $I_F = 5\text{mA}$, $V_{CE} = 5\text{V}$
- High isolation performance with 3,750V_{rms} input-output isolation voltage (V_{iso})
- Rated for a maximum collector-emitter voltage of 80V (V_{CEO})
- 4-Pin, Single Channel, Mini-flat package.
- UL 1577 Certified
- VDE DIN EN60747-5-5 Approved
- Fully compliant with RoHS regulations (EU RoHS directive No. 2002/95/EC, 2011/65/EU, and 2015/863)
- MSL Class 1, ensuring minimal sensitivity to moisture and ideal for automated assembly

APPLICATIONS

- Ideal for signal transmission and complete noise isolation
- Battery Management Systems (BMS)
- Precision measuring instruments
- Data communication and IT equipment applications
- Power-management circuits (PMCs)
- EV & Hybrid Electric Industry

ABSOLUTE MAXIMUM RATINGS ($T_A = 25^\circ\text{C}$)

Stresses exceeding the absolute maximum ratings can cause permanent damage to the device. Exposure to absolute maximum ratings for long periods of time can adversely affect reliability.

Input

Forward Current	50mA
Reverse Voltage	6V
Power dissipation	70mW
Junction Temperature	125°C

Output

Collector to Emitter V_{CEO}	80V
Emitter to Collector V_{ECO}	7V
Collector Power Dissipation	150mW
Junction Temperature	125°C

Total Package

Isolation Voltage	3750V _{RMS}
Total Power Dissipation	170mW
Operating Temperature	-55 to 125°C
Storage Temperature	-55 to 150 °C
Lead Soldering Temperature (10s)	260°C

ISOCOM COMPONENTS 2004 LTD

Unit 25B, Park View Road West, Park View Industrial Estate
Hartlepool, Cleveland, TS25 1PE, United Kingdom
Tel : +44 (0)1429 863 609 Fax : +44 (0)1429 863 581
e-mail : sales@isocom.co.uk
<http://www.isocom.com>

ISOCOM COMPONENTS ASIA LTD

Hong Kong Office
Block A, 8/F, Wah Hing Industrial Mansions
36 Tai Yau Street, San Po Kong, Kowloon, Hong Kong
Tel : +852 2995 9217 Fax : +852 8161 6292
e-mail : sales@isocom.com.hk



ISPQ9185X

ELECTRICAL CHARACTERISTICS ($T_A = 25^\circ\text{C}$ unless otherwise specified)

INPUT

Parameter	Symbol	Test Condition	Min	Typ.	Max	Unit
Forward Voltage	V_F	$I_F = 10\text{ mA}$	-	-	1.6	V
Reverse Current	I_R	$V_R = 4\text{ V}$	-	-	10	μA
Terminal Capacitance	C_t	$V = 0, f = 1\text{ KHz}$	-	30	250	pF

OUTPUT

Parameter	Symbol	Test Condition	Min	Typ.	Max	Unit
Dark Current	I_{CEO}	$V_{CE} = 48\text{ V}, I_F = 0\text{ mA}$	-	-	0.1	μA
Collector - Emitter Breakdown Voltage	BV_{CEO}	$I_C = 0.5\text{ mA}, I_F = 0\text{ mA}$	80	-	-	V
Emitter - Collector Breakdown Voltage	BV_{ECO}	$I_E = 0.1\text{ mA}, I_F = 0\text{ mA}$	7	-	-	V

TRANSFER

Parameter	Symbol	Test Condition	Min	Typ.	Max	Unit
Collector Current	I_C	$I_F = 5\text{ mA}, V_{CE} = 5\text{ V}$	2.5	-	30	mA
Current Transfer Ratio	CTR	$I_F = 5\text{ mA}, V_{CE} = 5\text{ V}$	50	-	600	%
Collector-Emitter Saturation Voltage	$V_{CE(sat)}$	$I_F = 8\text{ mA}, I_C = 2.4\text{ mA}$	-	-	0.4	V
Isolation Resistance	R_{iso}	500V DC, 40–60% RH	5×10^{10}	1×10^{11}	-	Ω
Floating Capacitance	C_f	$V=0, f=1\text{MHz}$	-	0.6	1	pF
Response Time (Rise)	t_r	$V_{CE} = 2\text{ V}, I_C = 2\text{ mA}, R_L = 100\Omega$	-	4	18	μs
Response Time (Fall)	t_f	$V_{CE} = 2\text{ V}, I_C = 2\text{ mA}, R_L = 100\Omega$	-	3	18	μs

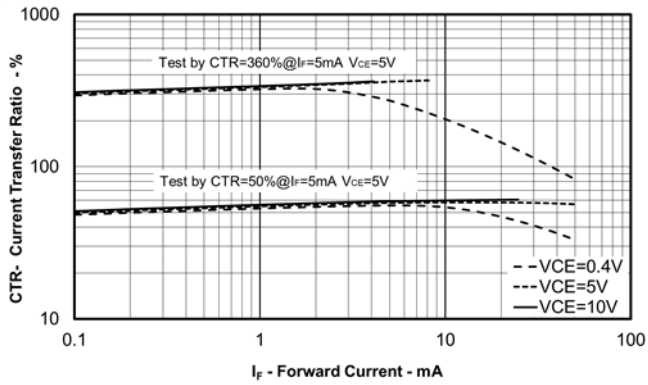

Fig 1 CTR vs Forward Current

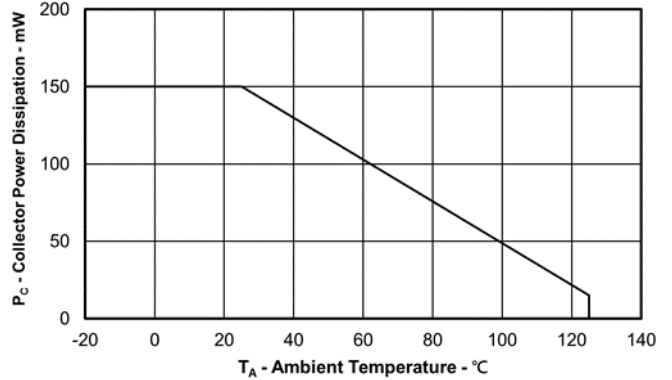

Fig. 2 Collector Dissipation vs Ambient Temp

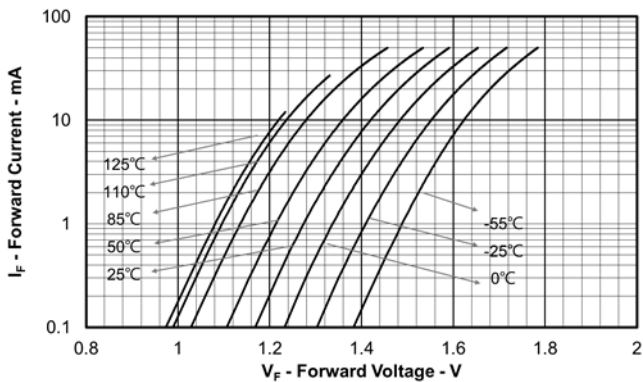

Fig. 3 Forward current vs Forward Voltage

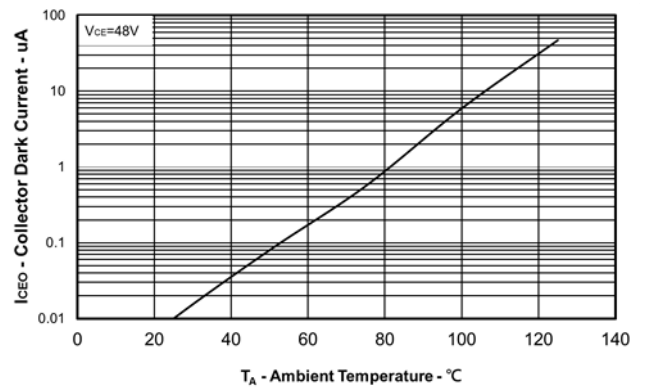

Fig 4 Dark Current vs Ambient Temp

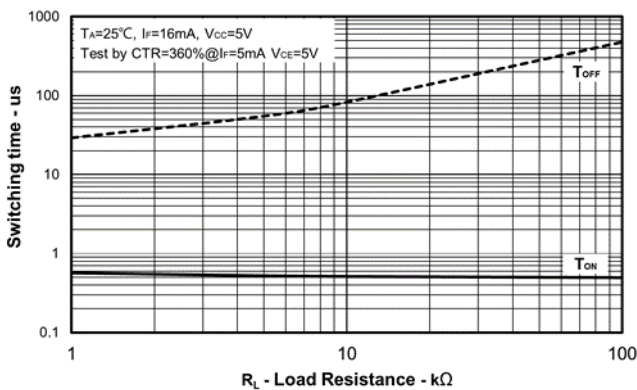

Fig. 5 Response time vs Load

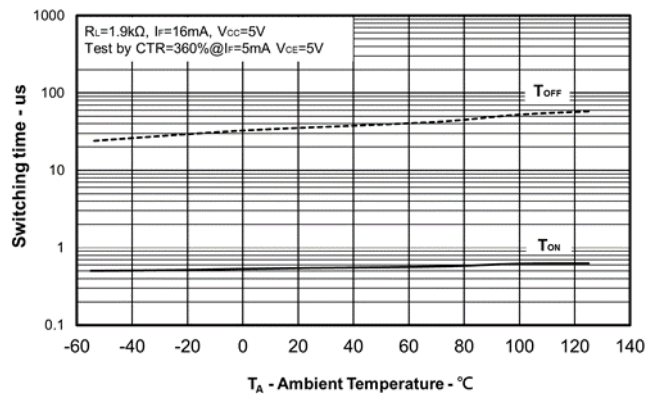

Fig. 6 Response time vs Ambient Temp



ISOCOM
COMPONENTS

ISPQ9185X

ORDER INFORMATION

ISPQ9185X			
After PN	PN	Description	Packing quantity
None	ISPQ9185X	SMT MINI-FLAT T&R	3000

DEVICE MARKING

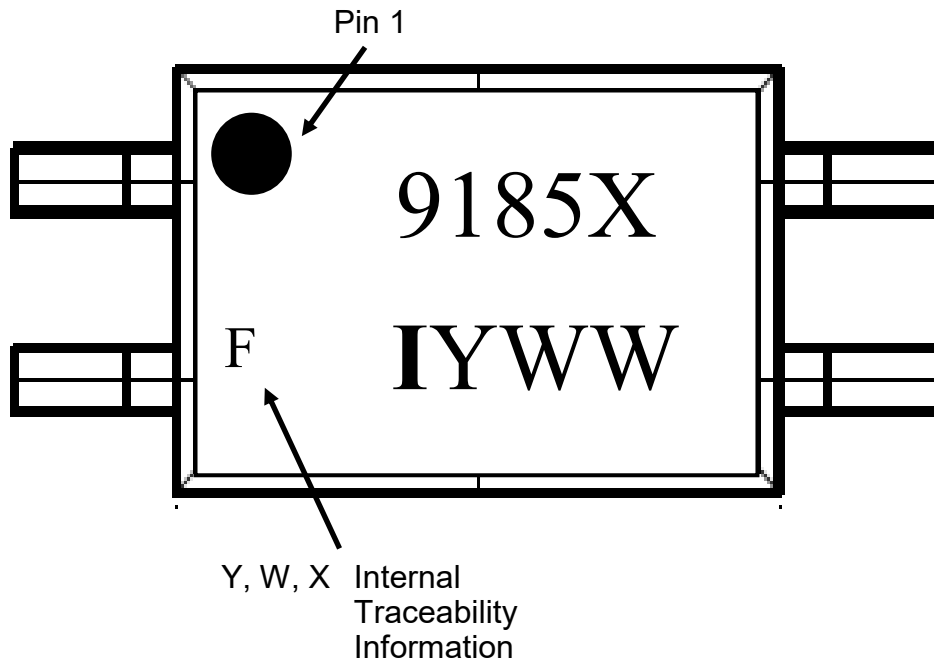

9185X	Device Part Number
I	Isocom Components 2004 Ltd.
N	Year code (P= 2025,Q = 2026, etc.)
WW	2 digit Week code

PACKAGE DIMENSIONS

4-Pin Mini Flat

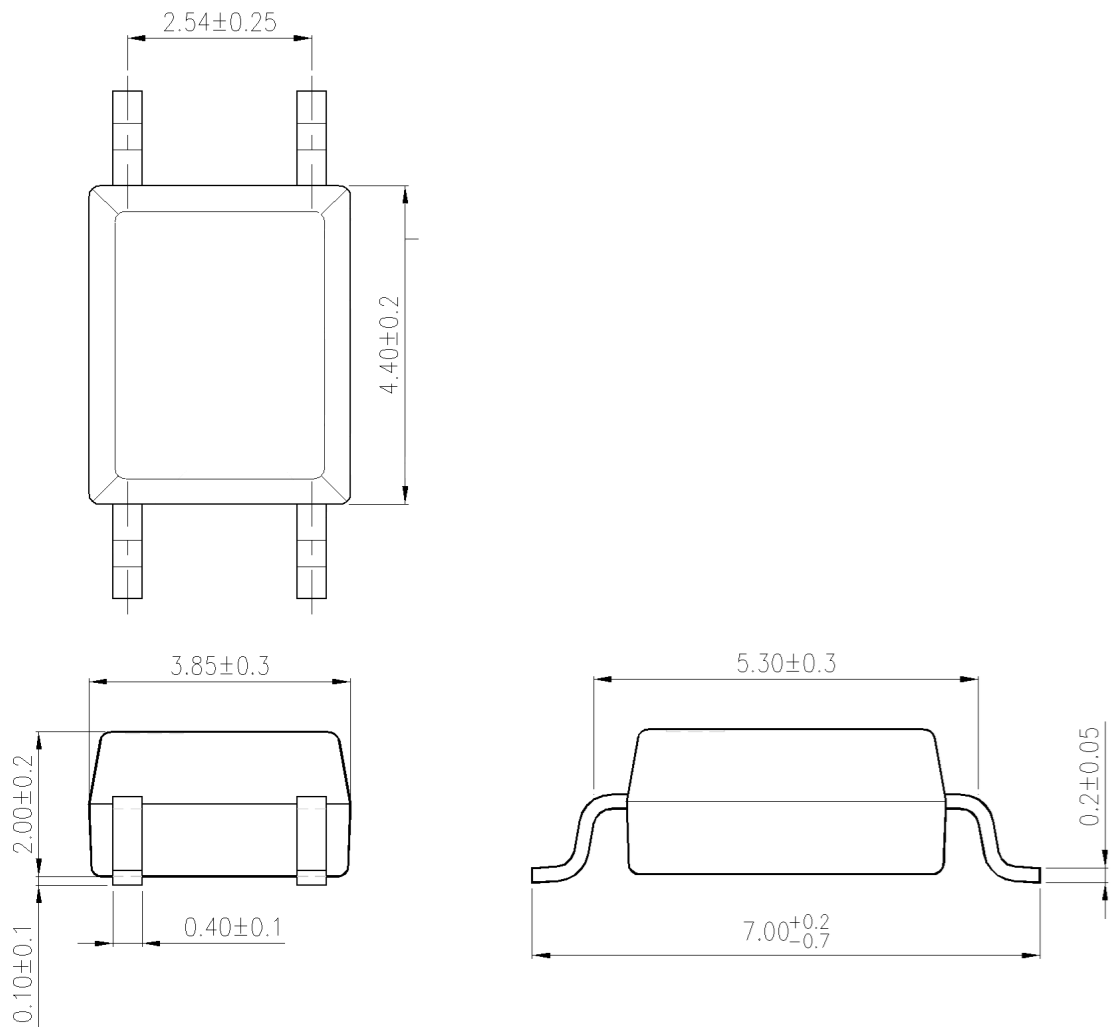

ISPQ9185X

RECOMMENDED PAD LAYOUT FOR SMD (mm)

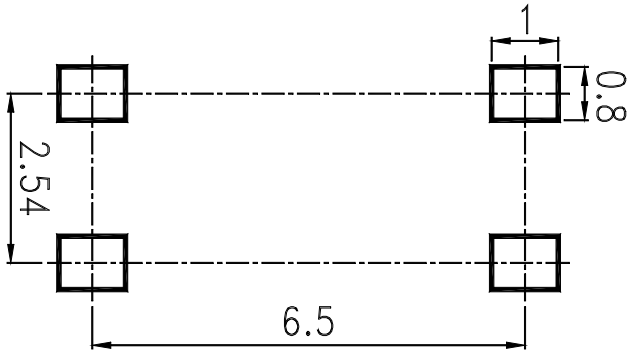

TAPE AND REEL PACKAGING

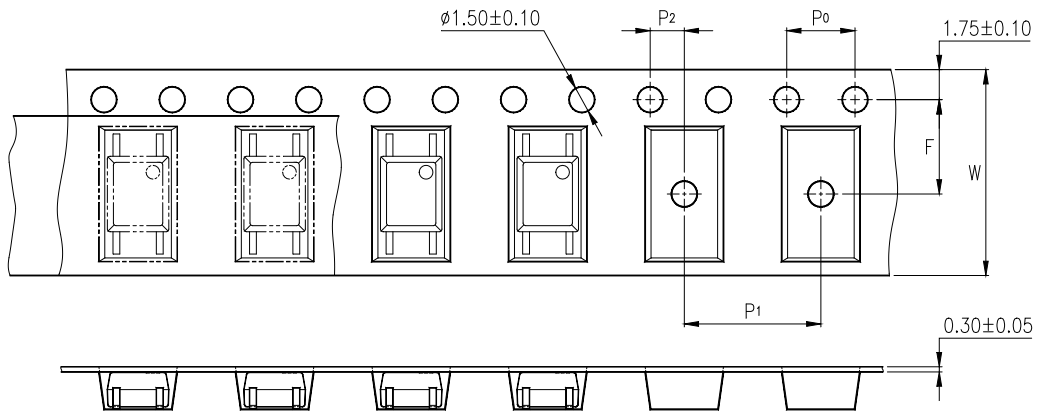

Description	Symbol	Dimension mm (inch)
Tape Width	W	12 ± 0.3 (0.47)
Pitch of Sprocket Holes	P_0	4 ± 0.1 (0.15)
Distance of Compartment to Sprocket Holes	F	5.5 ± 0.1 (0.217)
	P_2	2 ± 0.1 (0.079)
Distance of Compartment to Compartment	P_1	8 ± 0.1 (0.315)

IR REFLOW SOLDERING TEMPERATURE PROFILE

Note : One Time Reflow Soldering is Recommended.
Do Not Immerse Device Body in Solder Paste.

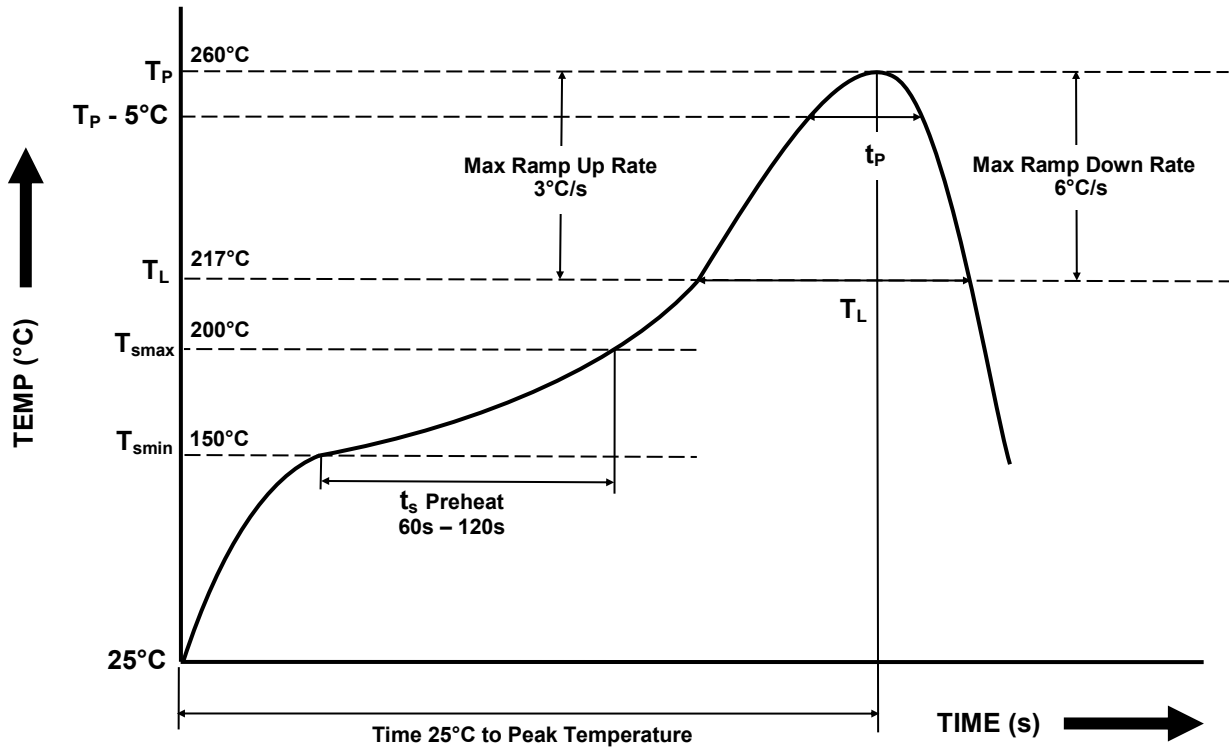

Profile Details	Conditions
Preheat - Min Temperature (T _{SMIN}) - Max Temperature (T _{SMAX}) - Time T _{SMIN} to T _{SMAX} (t _s)	150°C 200°C 60s - 120s
Soldering Zone - Peak Temperature (T _P) - Time at Peak Temperature - Liquidous Temperature (T _L) - Time within 5°C of Actual Peak Temperature (T _P - 5°C) - Time maintained above T _L (t _L) - Ramp Up Rate (T _L to T _P) - Ramp Down Rate (T _P to T _L)	260°C 10s max 217°C 30s max 60s - 100s 3°C/s max 6°C/s max
Average Ramp Up Rate (T _{smax} to T _P)	3°C/s max
Time 25°C to Peak Temperature	8 minutes max



ISPQ9185X

Disclaimer

Isocom Components is continually working to improve the quality and reliability of its products. Nevertheless, semiconductor devices in general can malfunction or fail due to their inherent electrical sensitivity and vulnerability to physical stress. It is the responsibility of the buyer, when utilizing Isocom Components products, to comply with the standards of safety in making a safe design for the entire system, and to avoid situations in which a malfunction or failure of such Isocom Components products could cause loss of human life, bodily injury or damage to property.

In developing your designs, please ensure that Isocom Components products are used within specified operating ranges as set forth in the most recent Isocom Components products specifications.

The Isocom Components products listed in this document are intended for usage in general electronics applications (computer, personal equipment, office equipment, measuring equipment, industrial robotics, domestic appliances, etc.). These Isocom Components products are neither intended nor warranted for usage in equipment that requires extraordinarily high quality and/or reliability or a malfunction or failure of which may cause loss of human life or bodily injury ("Unintended Usage"). Unintended Usage include atomic energy control instruments, airplane or spaceship instruments, transportation Instruments, traffic signal instruments, combustion control instruments, medical Instruments, all types of safety devices, etc... Unintended Usage of Isocom Components products listed in this document shall be made at the customer's own risk.

The products described in this document are subject to the foreign exchange and foreign trade laws.

The information contained herein is presented only as a guide for the applications of our products. No responsibility is assumed by Isocom Components for any infringements of intellectual property or other rights of the third parties which may result from its use. No license is granted by implication or otherwise under any intellectual property or other rights of Isocom Components or others.

The information contained herein is subject to change without notice.



Document Change Log

Date	Document Number	Change
07/07/2025	DN93336-01	Initial Release